



Geotextile Sand Filter

Pennsylvania

Design and Installation Manual

February, 2011



125 McKee Street
East Hartford, CT 06108
Tel: 800-444-1359 • Fax: 860-610-0427
www.eljen.com

Table of Contents

SUBJECT	PAGE
GLOSSARY OF TERMS.....	3
GSF SYSTEM DESCRIPTION	5
TESTING AND PERFORMANCE	6
1.0 DESIGN AND INSTALLATION	7
GSF SIZING EXAMPLE – GRAVITY IN-GROUND TRENCH DESIGN.....	11
GSF SIZING EXAMPLE – PRESSURE DOSING IN-GROUND TRENCH DESIGN	12
GSF SIZING EXAMPLE – GRAVITY IN-GROUND BED DESIGN	14
GSF SIZING EXAMPLE – PRESSURE DOSING IN-GROUND BED DESIGN	15
GSF SIZING EXAMPLE – PRESSURE DOSED MOUND DESIGN.....	16
GSF SIZING EXAMPLE – LESS THAN 20 INCHES FROM LIMITING HORIZON	18
2.0 TRENCH INSTALLATION GUIDELINES.....	20
3.0 BED INSTALLATION GUIDELINES	21
4.0 ELEVATED GSF SAND MOUND INSTALLATION GUIDELINES	22
5.0 DOSING DISTRIBUTION GUIDANCE	24
6.0 PRESSURE DISTRIBUTION GUIDANCE	24
7.0 PUMP CONTROLS	28
8.0 SYSTEM VENTILATION.....	29
ELJEN INSTALLATION CHECK LIST.....	34

GSF DRAWINGS AND TABLES

DRAWINGS:

FIGURE 1: GSF SYSTEM OPERATION	5
FIGURE 2: TRENCH CROSS SECTION FOR PERCOLATION RATES FROM 3 MIN/IN – 60 MIN/IN.....	7
FIGURE 3: TRENCH CROSS SECTION FOR PERCOLATION RATES FROM 61 MIN/IN – 180 MIN/IN.....	7
FIGURE 4: MINIMUM VERTICAL ISOLATION DISTANCES FOR FINAL TREATMENT	9
FIGURE 5: B43 GRAVITY IN-GROUND TRENCH – 3 BEDROOM – 31 MIN/INCH.....	11
FIGURE 6: B43 PRESSURE DOSING IN-GROUND TRENCH – 3 BEDROOMS – 31 MIN/INCH	12
FIGURE 7: B43 PRESSURE DOSING IN-GROUND TRENCH – 3 BEDROOMS – 61 MIN/INCH.....	13
FIGURE 8: B43 GRAVITY IN-GROUND BED – 3 BEDROOMS – 31 MIN/INCH.....	14
FIGURE 9: B43 PRESSURE DOSING IN-GROUND BED – 3 BEDROOMS – 31MIN/INCH	15
FIGURE 10: B43 PRESSURE DOSED MOUND DESIGN – 3 BEDROOMS – 61 MIN/INCH	17
FIGURE 11: B43 PRESSURE DOSED MOUND DESIGN – 3 BEDROOMS – 61 MIN/INCH	17
FIGURE 12: LESS THAN 20 INCHES FROM LIMITING HORIZON PLAN VIEW	19
FIGURE 13: LESS THAN 20 INCHES FROM LIMITING HORIZON CROSS SECTION	19
FIGURE 14: B43 SINGLE LATERAL MOUND SYSTEM.....	23
FIGURE 15: B43 MULTIPLE LATERAL MOUND SYSTEM	23
FIGURE 16: B43 MULTIPLE LATERAL MOUND SYSTEM	23
FIGURE 17: LIFT PUMP TO DISTRIBUTION BOX – GRAVITY FED – PLAN VIEW	24
FIGURE 18: PRESSURE PIPE PLACEMENT.....	25
FIGURE 19: CONTOURED TRENCH PRESSURE DISTRIBUTION.....	26
FIGURE 20: PLAN VIEW FOR PRESSURE DISTRIBUTION.....	26
FIGURE 21: EXAMPLE PRESSURE DISTRIBUTION	27
FIGURE 22: PRESSURE CLEAN OUT PRESSURE DOSED SYSTEM.....	27
FIGURE 23: VENT FOR GRAVITY AND DEMAND DOSED SYSTEMS.....	29
FIGURE 24: GSF WITH 4" VENT EXTENDED TO CONVENIENT LOCATION	30
FIGURE 25: AIR BY-PASS LINE PLAN VIEW; VENTING OF PUMPED SYSTEMS	30
FIGURE 26: AIR BY-PASS LINE CROSS SECTION; VENTING OF PUMPED SYSTEM.....	31

TABLES

TABLE 1: SPECIFIED SAND SIEVE REQUIREMENTS.....	4
TABLE 2: TESTING RESULTS	6
TABLE 3: GSF INSPECTION CHECK LIST	32

Glossary of Terms

B43 Module	Dimensions – 48" x 36" x 7" (L x W x H)
Bio-Matt™ fabric	Special filter fabric within the Geotextile Sand Filter Modules upon which the primary biomat layer forms.
Cover Fabric	The geotextile cover fabric (provided by manufacturer) that is placed over the GSF modules.
Cusped Core	The rigid plastic core of the GSF module. It separates the geotextile fabric and creates downward infiltration channels and upward aeration channels to provide primary filtration and biological treatment of the septic effluent. The curvilinear shape of the cusped core offers increased treatment surface area and greater effluent storage.
Design Flow	The estimated peak daily flow that is used to size a GSF system, and is in accordance with <i>Chapter 73</i> .
Distribution Box	A plastic or concrete box that receives effluent from a septic tank and splits the flow to pipes placed above the GSF modules. For equal distribution, the outlet pipe orifices are typically set at the same elevation to equalize the flow to each line.
Flow Dial/Equalizer	Special insert placed in the end of distribution pipes within the distribution box to compensate for possible unlevel installation and promote favorable flow to the distribution pipes.
GSF	The Eljen Geotextile Sand Filter modules and the sand layer along the base and sides of the modules.
GSF Module	The individual module of a GSF system. The module is comprised of a cusped plastic core and corrugated geotextile fabric.
LTAR	Long Term Acceptance Rate (LTAR) is the average equilibrium absorption rate for effluent in a system, usually expressed in gallons per day per square foot. It should not be confused with the design loading rate that is used by regulatory officials in their regulations.
SHWT	Seasonal High Water Table.

Glossary of Terms

Specified Sand

To ensure proper system operation, the system must be installed with ASTM C33 SAND. Sand must be a medium to coarse, washed, silica sand with not more than 10% passing the #100 Sieve and not more than 5% passing the # 200 sieve. Alternatively, PA DOT Type A (Cement Concrete Sand) sand may be used. Ask your material supplier for a sieve analysis to verify that your material meets the required specifications.

TABLE 1: SPECIFIED SAND SIEVE REQUIREMENTS

ASTM C33 SAND SPECIFICATION		
Sieve Size	Sieve Square Opening Size	Specification Percent Passing (Wet Sieve)
3/8 inch	9.5 mm	100 – 100
No. 4	4.75 mm	95 – 100
No. 8	2.36 mm	80 – 100
No. 16	1.18 mm	50 – 85
No. 30	600 µm	25 – 60
No. 50	300 µm	5 – 30
No. 100	150 µm	0 – 10
No. 200	75 µm	0 - 5

STE

Septic Tank Effluent (STE) is anaerobically digested effluent that is discharged to a Geotextile Sand Filter module for further treatment.

Width & Length

The system width is the sand dimension perpendicular to the GSF module rows. The system length is measured parallel to the rows of GSF modules.

Wire Clamp

Wire Clamps are used to secure perforated pipe above the GSF modules.

GSF System Description

The Eljen GSF Geotextile Sand Filter system is a cost-effective alternative to other septic technologies. Comprised of a proprietary two-stage Bio-Matt™ pre-treatment process, the geotextile modules apply a better-than-secondary aerobic effluent to the soil, increasing the soil's ability to accept the effluent. The result is superior treatment in a smaller soil absorption area.

How the GSF System Works

Primary Treatment Zone

- Perforated pipe is centered above the GSF module to distribute septic effluent over and into corrugations created by the cusped core of the geotextile module.
- Septic effluent is filtered through the Bio-Matt fabric. The module's unique design provides increased surface area for biological treatment that greatly exceeds the module's footprint.
- Open air channels within the module support aerobic bacterial growth on the modules geotextile fabric interface, surpassing the surface area required for traditional absorption systems.
- An anti-siltation geotextile fabric covers the top and sides of the GSF module and protects the Specified Sand and soil from clogging, while maintaining effluent storage within the module.

Secondary Treatment Zone

- Effluent drips into the Specified Sand layer and supports unsaturated flow into the native soil. This Specified Sand/soil interface maintains soil structure, thereby maximizing the available absorption interface in the native soil. The Specified Sand supports nitrification of the effluent, which reduces oxygen demand in the soil, thus minimizing soil clogging from anaerobic bacteria.
- The Specified Sand layer also protects the soil from compaction and helps maintain cracks and crevices in the soil. This preserves the soil's natural infiltration capacity, which is especially important in finer textured soils, where these large channels are critical for long-term performance.
- Native soil provides final filtration and allows for groundwater recharge.

FIGURE 1: GSF SYSTEM OPERATION

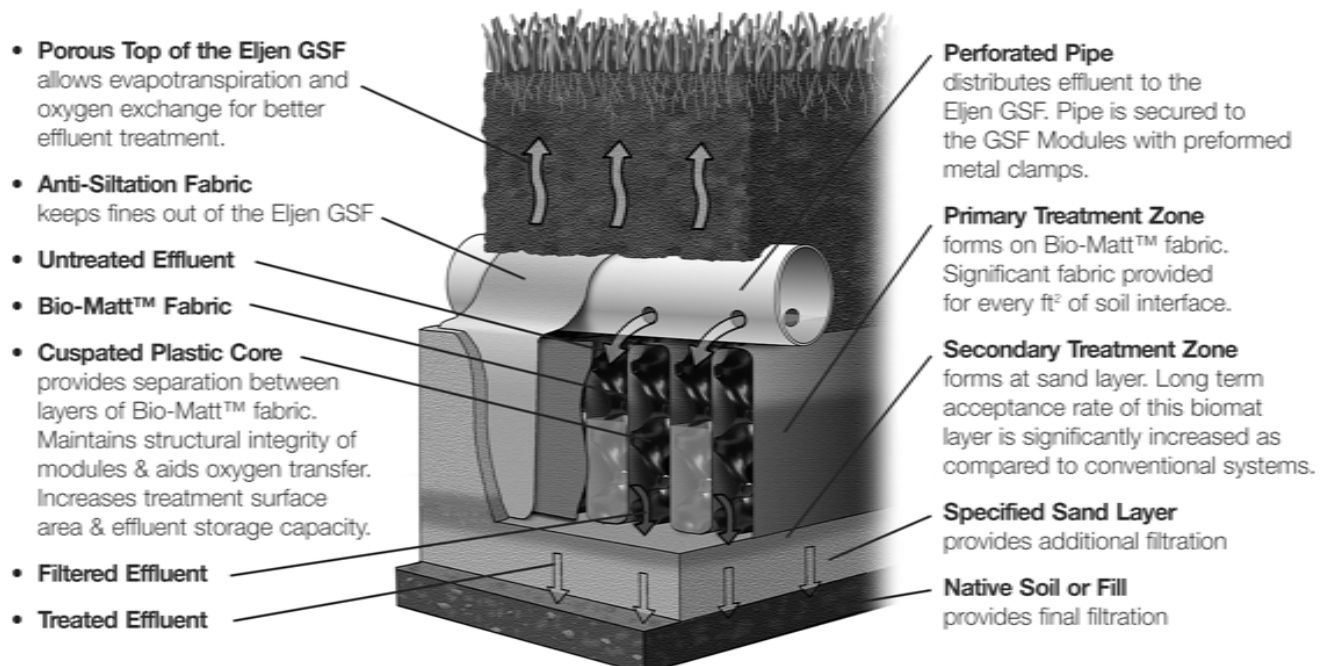

Testing and Performance

GSF Modules were subjected to independent third-party testing in accordance with NSF/ANSI Standard 40 Protocol. Three different methods of distribution were tested:

- Pressure Distribution
- Lift Pump/Gravity Demand Dosed Distribution
- Gravity Distribution

The data and detailed reports for each system tested were reviewed by NSF in accordance with NSF/ANSI Standard 40 Protocol and the Pennsylvania Department of Environmental Protection Technical Verification Program. This independent review validates the performance data listed below for Demand Dosed, Pressure Dosed, and Gravity systems.

Testing Arrangement & Common Factors:

Common Factors for all tested systems listed in Table 2:

- A42 modules: (L x W x H) 48" x 24" x 7" plus Specified Sand.
- Six modules per bedroom at 150 gal/day, 18 modules total for three bedrooms per house equals 450 gal/day.
- Standard distribution pipe with orifices at the 5 & 7 o'clock position,
- 12 inches of Specified Sand base extending 6 inches at either edge of the modules.

Lift Pump/Gravity Demand Dosed System:

- 1000 gal septic tank – 500 gallon pump chamber to distribution box.
- Dial-a-flow fittings set level to deliver effluent into each of the three rows of laterals via a 4-inch perforated distribution pipe with orifices at the 5 & 7 o'clock position.
- A non-perforated pipe connects the distal end to the end of other rows.

Time Pressure Dosed System:

- 1000 gal septic tank – 500 gal pump chamber – 1.25" low-pressure pipe (LPP) or other diameter as required.
- LPP placed inside a 4-inch perforated distribution pipe with orifices at 12 o'clock, at least one drain hole per line at 6 o'clock.
- The 4-inch perforated pipe orifices are placed at the 5 & 7 o'clock positions with the end of pipe capped

Gravity System Trench Design:

- 1000 gal septic tank–gravity to distribution box.
- Dial-a-flow fittings set level to deliver influent into three individual trenches.
- Perforated distribution pipe with orifices at the 5 & 7 o'clock positions with the end of pipe capped.

TABLE 2: TESTING RESULTS

GSF Modules Treatment Performance NSF Standard 40 Protocol Wastewater Influent Median Characteristics: CBOD 180 mg/L & TSS 180 mg/L		
Demand Dosed		
	CBOD (mg/L)	TSS (mg/L)
Mean	2.0	2.7
Median	1.0	2.5
Min Value	1.0	2.5
Max Value	7.2	7.0

GSF Modules Treatment Performance NSF Standard 40 Protocol Wastewater Influent Median Characteristics: CBOD 180 mg/L & TSS 190 mg/L		
Timed Pressure Dosed		
	CBOD (mg/L)	TSS (mg/L)
Mean	2.6	2.7
Median	2.2	2.5
Min Value	1.0	2.5
Max Value	14.0	9.0

GSF Modules Treatment Performance NSF Standard 40 Protocol Wastewater Influent Median Characteristics: CBOD 180 mg/L & TSS 180 mg/L		
Gravity		
	CBOD (mg/L)	TSS (mg/L)
Mean	8.0	7.4
Median	7.6	5.0
Min Value	1.0	2.5
Max Value	18	55
TSS 2.5mg/L = sample was below detection limits		
CBOD 1.0mg/L = sample was below detection limits		

1.0 Design and Installation

FIGURE 2: TRENCH CROSS SECTION FOR PERCOLATION RATES FROM 3 MIN/IN – 60 MIN/IN

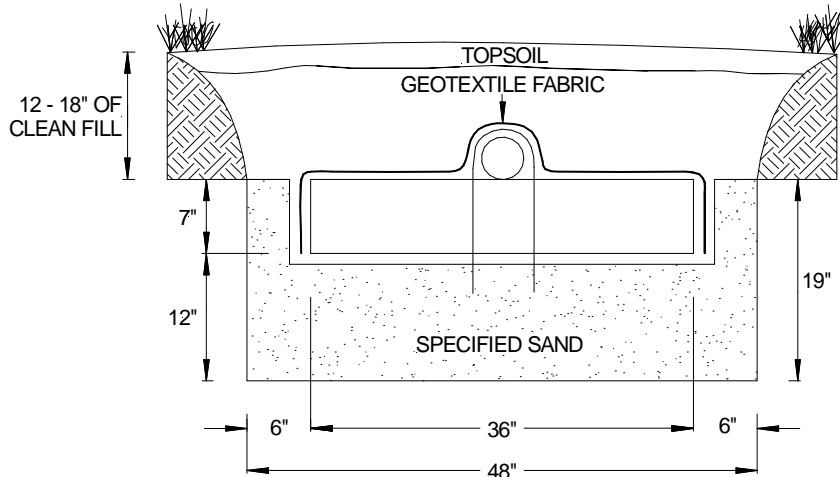

- 6 inches of Specified Sand is required at the edges of the GSF module.
- 6 inches minimum of Specified Sand is required at the beginning and end of each GSF Trench.
- 12 inches minimum of Specified Sand is required directly below the GSF module.
- Minimum 12 inches of clean fill above modules.

FIGURE 3: TRENCH CROSS SECTION FOR PERCOLATION RATES FROM 61 MIN/IN – 180 MIN/IN

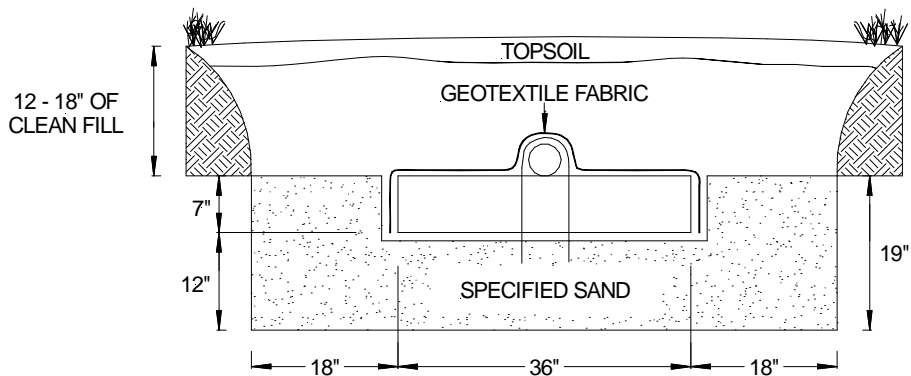

- 18 inches of Specified Sand is required at the edges of the GSF module.
- 6 inches minimum of Specified Sand is required at the beginning and end of each GSF Trench.
- 12 inches minimum of Specified Sand is required directly below the GSF module.
- Minimum 12 inches of clean fill above modules.

1.0 Design and Installation

1.1 REQUIREMENTS: GSF Design and Installation must meet Pennsylvania Title 25, Chapter 73 (hereinafter the *Guidelines*), except as outlined in this manual.

The sizing information in Section 1.16 of this manual applies to domestic strength wastewater only. Please contact Eljen's Technical Resource Department at 1-800-444-1359 for design information on systems not covered in this manual.

1.2 SPECIFIED SAND SPECIFICATION FOR GSF SYSTEMS: Specified Sand immediately under, between rows, and around the perimeter of the GSF system must be an **ASTM C33 WASHED CONCRETE SAND WITH LESS THAN 10% PASSING A #100 SIEVE AND LESS THAN 5% PASSING A #200 SIEVE**. Alternatively, PA DOT Type A (Cement Concrete Sand) sand may be used. Ask your material supplier for a sieve analysis to verify that your material meets the required specifications. Please place a prominent note to this effect on each design drawing. See Table 1 for more information on the ASTM C33 sand and sieve specifications.

1.3 CONNECTIONS AND FITTINGS: Connections of lines to tanks and distribution boxes must be made in accordance with local codes and regulations.

1.4 PLACING GSF MODULES: Each row of modules is laid level and end to end on the above Specified Sand. No mechanical connection is required between modules.

1.5 DISTRIBUTION PIPE: SDR-35 or equivalent is required. Place perforated distribution pipe on top of GSF modules with holes at 5 and 7 o'clock. Secure pipe to GSF modules with provided wire clamps, one clamp per Eljen module. All distribution piping must meet a minimum 2,500 pound crush test specification or meet the requirements of the most recent revision of ASTM D 2665 for polyvinyl chloride (PVC) drain, waste and vent pipe. Configuration of the distribution pipe changes for pressure distribution. Refer to Section 6.0 for further guidance.

1.6 DISTRIBUTION BOX: Set the gravity system D-box outlet invert a minimum of 1/8 inch drop in elevation per linear foot to the top first module in the row. Set a 2-inch minimum drop for dosed systems from the D-box to the modules. Ensure that the distribution box and pipes feeding the system are placed on settled soil. Flow Dials may be used in either Gravity or Dosed installations.

1.7 COVER FABRIC: Geotextile cover fabric is provided by Eljen Corporation for all GSF systems. It is placed over the top and sides of the module rows to prevent long term siltation and failure. Cover fabric substitution is **NOT** allowed. Fabric should drape vertically over the pipe and must **NOT** block holes in the distribution pipe or be stretched from the top of the pipe to the outside edge of the modules. "Tenting" will cause undue stress on fabric and pipe.

1.8 BACKFILL & FINISH GRADING: Complete backfill with a minimum of 12 inches of clean porous fill measured from the top of modules. Use backfill material that is soil suitable for the growth of vegetation, and be seeded to control erosion. Do not use wheeled equipment over the system. A light track machine may be used with caution, avoiding crushing or shifting of pipe assembly. Divert surface runoff from the Effluent Disposal Area, (EDA). Finish grade to prevent surface ponding. Add topsoil and seed to the system area to protect from erosion.

1.0 Design and Installation

1.9 VERTICAL ISOLATION SEPARATION: For final treatment and disposal for an at-grade absorption area, the minimum vertical isolation distances for this final treatment option are greater than or equal to 10 inches to the seasonal high water table, or greater than or equal to 16 inches to rock formation.

FIGURE 4: MINIMUM VERTICAL ISOLATION DISTANCES FOR FINAL TREATMENT

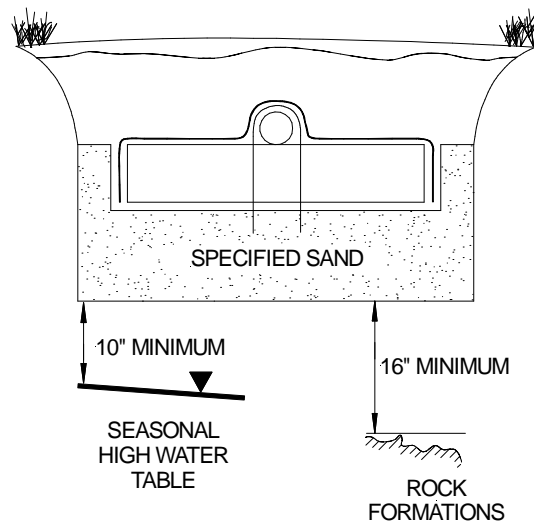

1.10 LIMITING ZONES GREATER THAN OR EQUAL TO 20 INCHES FROM THE MINERAL SOIL SURFACE:

An at-grade absorption area designed in accordance with the alternate at-grade system standards in Part 9 of the February 6, 2004 Alternate Systems Guidance (ASG) (Document ID 362-0300-007) may be used, except that the soil profile must show that there is a minimum 20 inches of suitable soil between the bottom of the proposed absorption area and the limiting zone rather than the 48 to 60 inches of suitable soil or sand/soil required by Part 9. Where the percolation rate is in the range of 3 to 60 min/in, inclusive, up to a 40 percent reduction in the size of the absorption area is allowed. However, where the percolation rate is in the range of 61 to 180 min/in, inclusive, no reduction in absorption area sizing is permitted.

1.11 LIMITING ZONES LESS THAN 20 INCHES FROM THE MINERAL SOIL SURFACE: On sites exhibiting limiting zones less than 20 inches from the mineral surface, a minimum of four soil profile test pits shall be evaluated to verify the morphology of the proposed absorption site for an at-grade Eljen GSF System. These soil profiles shall include two soil profile evaluations on contour, bracketing the proposed absorption area, and two soil profile evaluations on contour, 50 feet down gradient from the absorption area.

1.12 MINIMUM LENGTH TO WIDTH REQUIREMENTS: A minimum 4:1 length to width ratio is recommended for slopes ranging from 8% to 12%. Slopes ranging from 12% to 15% may utilize a 6:1 length to width ratio or greater. There is no minimum length to width ratio for slopes less than 8%.

1.13 MINIMUM SEPARATION DISTANCE BETWEEN IN-GROUND TRENCHES: There is a minimum 5-foot separation between trenches, measured from sidewall to sidewall as per 73.52 (b) (7).

1.0 Design and Installation

1.14 SEPTIC TANK: Septic tank standards as set forth in Chapter 73, Section 31, must be adhered to for alternate system installations, with the following additional specifications:

- The septic tank capacity must be sized to have a minimum hydraulic retention time of 2.5 days, using estimated maximum daily sewage flows from Chapter 73.
- Septic tanks must be rectangular in shape.
- A septic tank consists of a dual compartment tank or two single compartment tanks connected in series. Two single compartment tanks connected in series are equivalent to one dual compartment tank.
- Measures to control flotation of the tank must be implemented when the tank is installed in areas below any indication of a water table.
- An effluent filter bearing the seal of NSF indicating testing and approval by that agency under Standard No. 46 must be installed on the outlet of the final tank or compartment.

1.15 ADDITIONAL FACTORS EFFECTING RESIDENTIAL SYSTEM SIZE: Homes with expected higher than normal water usage may consider increasing the septic tank volume. Consideration for disposal area may be up-sized for expected higher than normal water use.

For example:

- Luxury homes, homes with a Jacuzzi style tubs, and other high use fixtures.
- Homes with expected higher than normal occupancy.

1.16 GARBAGE DISPOSALS: Garbage disposals are not recommended to be used with the GSF system. Design drawings shall include a note "**Garbage disposals should not be used with this system**". However, if such units are proposed to be used, other measures must be taken to prevent solids from leaving the tank and entering the system such as:

- Increasing the septic tank capacity by a minimum of 30%, or
- Installation of a second septic tank installed in series, or
- Installation of an appropriate sized septic tank outlet effluent filter.

1.17 SIZING GSF SYSTEMS

When determining the correct sizing for your GSF system, it is important to follow your local codes and regulations for proper surface and subsurface classification as specified under Chapter 73, Section 17. Furthermore, refer to Chapter 73, Section 16, Table A for Absorption Area Requirements.

Important note: For final treatment and disposal for an onlot system **where the percolation rate is in the range of 3 to 60 minutes per inch (min/in), inclusive, up to a 40 percent reduction in the size of the absorption area is allowed.** However, where the percolation rate is in the range of 61 to 180 min/in, inclusive, no reduction in absorption area sizing is permitted.

When calculating the number of modules necessary, the effective bottom absorption area will be either 16 ft² per module for percolation rates between 3 min/in to 60 min/in or 24 ft² per module for percolation rates between 61 min/in to 180 min/in.

GSF Sizing Example – Gravity In-Ground Trench Design

Example #1 Gravity In-Ground Trench Design

House size – 3 bedrooms
 Design Flow – 400 gpd (Chapter 73.17)
 Percolation Rate – 31 min/in

Determine the absorption area for the trench:

Absorption area (ft²) based on the percolation rate and peak daily flow.
 For a percolation rate of 31 min/in: $((\text{Avg. Perc Rate} - 30) \times (0.030) + 1.79) = 1.82 \text{ ft}^2 \text{ per gallon (gal)}$.
 Absorption area of trench for 3 bedroom: $400 \text{ gal/day} \times 1.82 \text{ ft}^2/\text{gal} = 728 \text{ ft}^2$.

Reduce Trench Area by 40%: $728 \text{ ft}^2 \times (1 - 0.4) = 437 \text{ ft}^2$.

Determine number of Modules:

The B43 Module Basal Area is 16 ft² for percolation rates between 3 min/in – 60 min/in.
 Number of Modules = Reduced Trench Area ÷ B43 Basal Area: $437 \text{ ft}^2 \div 16 \text{ ft}^2 = 27.3$, use 28 Modules.

Determine length of trench: (Number of Modules x 4 ft) + 1 ft of Specified Sand:

$(28 \text{ modules} \times 4 \text{ ft}) + 1 \text{ ft} = 113 \text{ ft}$ of trench.

Length with Multiple Trenches:

$(\text{Number of Modules} \div \text{Number of Trenches} \times 4 \text{ ft}) + 1 \text{ ft}$ of Specified Sand = Length of Trenches.

2 Trenches: $28 \text{ Modules} \div 2 \text{ Trenches} = 14 \text{ Modules}$, use 14 Modules: $14 \text{ Modules} \times 4 \text{ ft} + 1 \text{ ft} = 57 \text{ ft}$ per trench.

Final Trench Layout Dimensions:

<i>2 Trenches</i>	
Length =	57 ft
Width =	4 ft
Installed Area =	456 ft ²
Number of Trenches =	2
Number of Modules =	28 B43
Spacing between Trenches =	5 ft

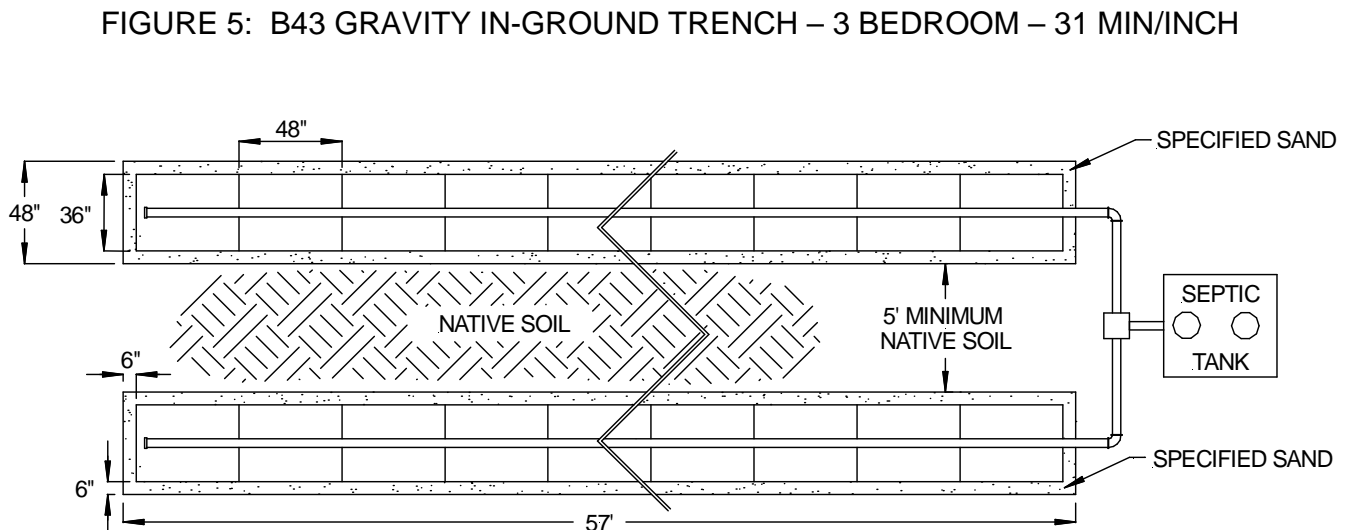

GSF Sizing Example – Pressure Dosing In-Ground Trench Design

Example #2 Pressure Dosing In-Ground Trench Design

House size – 3 bedrooms
 Design Flow – 400 gpd (Chapter 73.17)
 Percolation Rate – 31 min/in

Determine the absorption area for the trench:

Absorption area (ft²) based on the percolation rate and peak daily flow.
 For a percolation rate of 31 min/in: ((Avg. Perc Rate - 30) x (0.026) + 1.50) = 1.53 ft² per gallon (gal).
 Absorption area of trench for 3 bedroom: 400 gal/day x 1.53 ft²/gal = 612 ft².

Reduce Trench Area by 40%: 612 ft² x (1 - 0.4) = 367.2 ft².

Determine number of Modules:

The B43 Module Basal Area is 16ft² for percolation rates between 3 min/in – 60 min/in.
 Number of Modules = Reduced Trench Area ÷ B43 Basal Area: 367.2 ft² ÷ 16 ft² = 22.95, use 23 Modules.

Determine length of trench: (Number of Modules x 4 ft) + 1 ft of Specified Sand + 0.5 ft Lateral Offset:
 (23 modules x 4 ft) + 1 ft + 0.5 ft = 93.5 ft of trench.

Length with Multiple Trenches:

(Number of Modules ÷ Number of Trenches x 4 ft) + 1 ft of Specified Sand + 0.5 ft Lateral Offset = Length of Trenches.

2 Trenches: 23 Modules ÷ 2 Trenches = 11.5 Modules, use 12 Modules: 12 Modules x 4 ft + 1 ft + 0.5 ft = 49.5 ft per trench.

Final Trench Layout Dimensions:

2 Trenches	
Length =	49.5 ft
Width =	4 ft
Installed Area =	396 ft ²
Number of Trenches =	2
Number of Modules =	24 B43
Spacing between Trenches =	5 ft

FIGURE 6: B43 PRESSURE DOSING IN-GROUND TRENCH – 3 BEDROOMS – 31 MIN/INCH

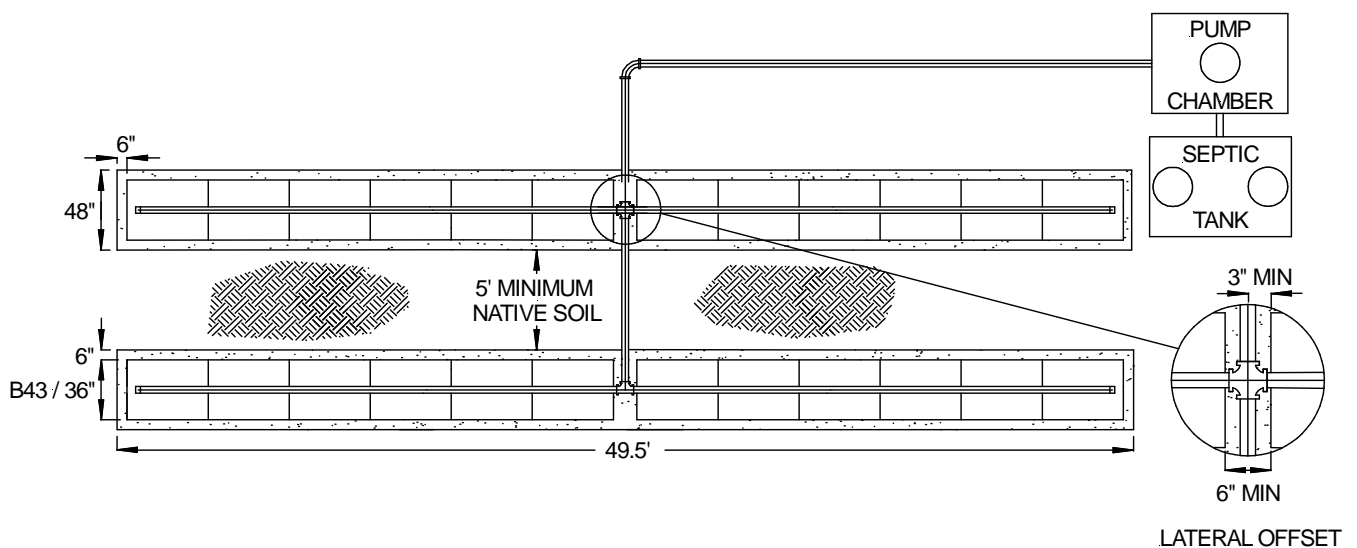

GSF Sizing Example – Pressure Dosing In-Ground Trench Design

Example #3 Pressure Dosing In-Ground Trench Design

House size – 3 bedrooms
 Design Flow – 400 gpd (Chapter 73.17)
 Percolation Rate – 61 min/in

Determine the absorption area for the trench:

Absorption area (ft²) based on the percolation rate and peak daily flow.
 For a percolation rate of 61 min/in: ((Avg. Perc. Rate - 60) x (0.020) + 2.22) = 2.24 ft² per gallon (gal).
 Absorption area of trench for 3 bedroom: 400 gal/day x 2.24 ft²/gal = 896 ft².

No reduction trench area (Perc Rate >60 mpi): 896 ft².

Determine number of Modules:

The B43 Module Basal Area is 24 ft² for percolation rates from 61 min/in – 180 min/in.
 Number of Modules = Reduced Trench Area ÷ B43 Basal Area: 896 ft² ÷ 24 ft² = 37.3, use 38 Modules.

Determine length of trench: (Number of Modules x 4 ft) + 1 ft of Specified Sand + 0.5 ft Lateral Offset:
 (38 modules x 4 ft) + 1 ft + 0.5 ft Lateral Offset = 153.5 ft of trench.

Length with Multiple Trenches:

(Number of Modules ÷ Number of Trenches x 4 ft) + 1 ft of Specified Sand + 0.5 ft Lateral Offset = Length of Trenches.

2 Trenches: 38 Modules ÷ 2 Trenches = 19 Modules, use 19 Modules:
 19 Modules x 4 ft + 1 ft + 0.5 ft = 77.5 ft per trench.

Final Trench Layout Dimensions:

<i>2 Trenches</i>	
Length =	77.5 ft
Width =	6 ft
Installed Area =	930 ft ²
Number of Trenches =	2
Number of Modules =	38 B43
Spacing between Trenches =	5 ft

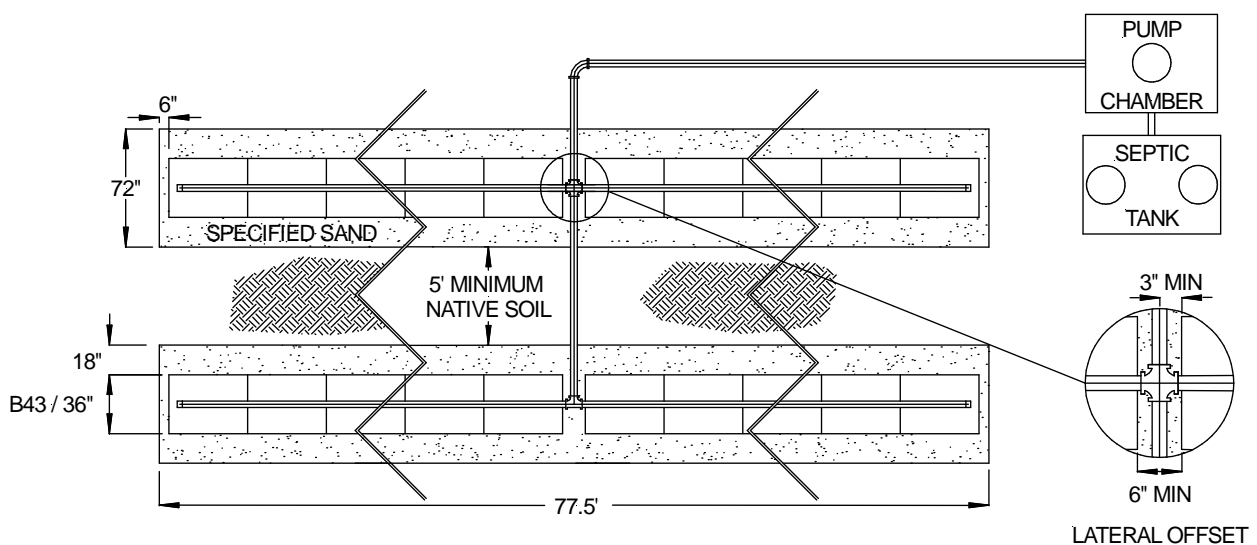

FIGURE 7: B43 PRESSURE DOSING IN-GROUND TRENCH – 3 BEDROOMS – 61 MIN/INCH

GSF Sizing Example – Gravity In-Ground Bed Design

Example #4 Gravity In-Ground Bed Design

House size – 3 bedrooms
 Design Flow – 400 gpd (Chapter 73.17)
 Percolation Rate – 31 min/in

Determine the square feet of bed per gallon per day:

Absorption area (ft²) based on the percolation rate and peak daily flow.

For a percolation rate of 31 min/in: ((Avg. Perc Rate - 30) x (0.030) + 1.79) = 1.82 ft² per gallon (gal).

Absorption area of a bed for 3 bedroom: 400 gal/day x 1.82 ft²/gal = 728 ft².

Reduce bed area by 40%: 728 ft² x (1 - 0.4) = 437 ft².

Determine number of modules:

The B43 Module Basal Area is 16ft² for percolation rates between 3 min/in – 60 min/in.

Number of Modules = Reduced Trench Area ÷ B43 Basal Area: 437 ft² ÷ 16 ft² = 27.3, use 28 Modules.

Calculate Bed Length:

(Number of Modules ÷ Number of Rows x 4 ft) + 1 ft of Specified Sand = Bed Length.

2 Rows: 28 Modules ÷ 2 Rows = 14 Modules: 14 Modules x 4 ft + 1 ft = 57 ft Bed Length.

Calculate Approximate Bed Width (for this example, we decided to use two rows):

Divide the bed area in square feet by bed length: 437 ft² ÷ 57 ft = 7.7 ft wide.

Determine the Module Row Spacing and Bed Width:

Minimum center to center separation distance between rows for percolation rates between 3 – 60 min/in = 4 ft

Minimum distance from sidewall = 4 ft ÷ 2 = 2 ft

Bed Width = 2 x (Minimum Distance from Sidewall) + ((Number of Rows - 1) x (Minimum separation distance between rows)) Bed Width = (2 x 2) + (1 x 4) = 8 ft

Final Bed Layout Dimensions:

Length =	57 ft
Width =	8 ft
Installed Area =	456 ft ²
Number of Rows =	2
Number of Modules =	28 B43
Center – Center Spacing =	4 ft
Edge – Center Spacing =	2 ft

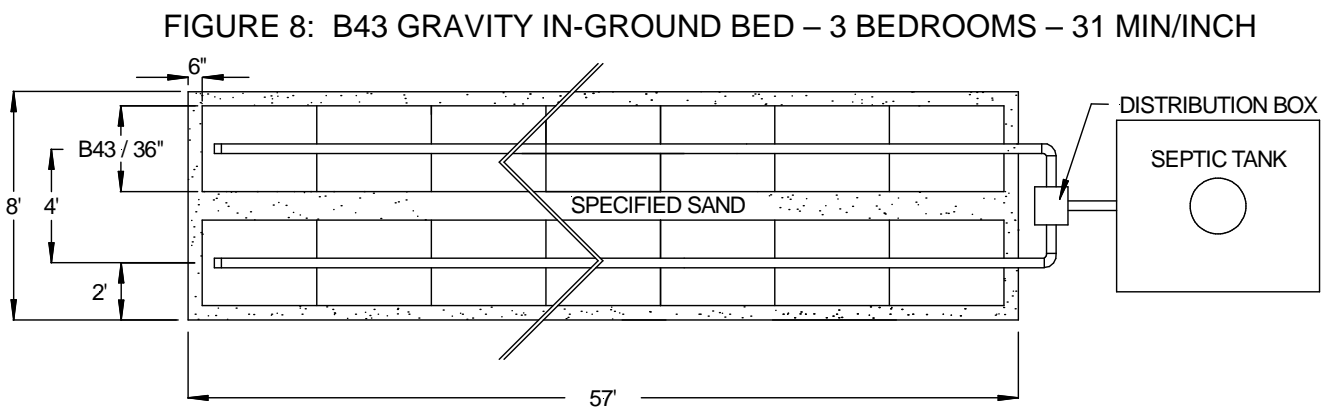

GSF Sizing Example – Pressure Dosing In-Ground Bed Design

Example #5 Pressure Dosing In-Ground Bed Design

House size – 3 bedrooms
 Design Flow – 400 gpd (Chapter 73.17)
 Percolation Rate – 31 min/in

Determine the square feet of bed per gallon per day:

Absorption area (ft²) based on the percolation rate and peak daily flow.
 For a percolation rate of 31 min/in: ((Avg. Perc Rate - 30) x (0.026) + 1.50) = 1.53 ft² per gallon (gal).
 Absorption area of a bed for 3 bedroom: 400 gal/day x 1.53 ft²/gal = 610 ft².

Reduce bed area by 40%: 610 ft² x (1 - 0.4) = 366 ft².

Determine number of modules:

The B43 Module Basal Area is 16ft² for percolation rates between 3 min/in – 60 min/in.
 Number of Modules = Reduced Trench Area ÷ B43 Basal Area: 366 ft² ÷ 16 ft² = 22.8, use 23 Modules.

Calculate Bed Length:

(Number of Modules ÷ Number of Rows x 4 ft) + 1 ft of Specified Sand + 0.5 ft Lateral Offset = Bed Length.
 2 Rows: 23 Modules ÷ 2 Rows = 11.5 Modules, use 12 Modules: 12 Modules x 4 ft + 1 ft + 0.5 ft = 49.5 ft Bed Length.

Calculate Approximate Bed Width (for this example, we decided to use two rows):

Divide the bed area in square feet by bed length: 366 ft² ÷ 49.5 ft = 7.4 ft wide, use 7.5 ft.

Determine the Module Row Spacing and Bed Width:

Minimum center to center separation distance between rows (measured center to center): 4 ft
 Minimum distance from sidewall = 4 ft ÷ 2 = 2 ft
 Bed Width = 2 x (Minimum Distance from Sidewall) + ((Number of Rows - 1) x (Minimum separation distance between rows)) Bed Width = (2 x 2) + (1 x 4) = 8 ft

Final Bed Layout Dimensions:

Length =	49.5 ft
Width =	8 ft
Installed Area =	396 ft ²
Number of Rows =	2
Number of Modules =	24 B43
Center - Center Spacing =	4 ft
Edge - Center Spacing =	2 ft

FIGURE 9: B43 PRESSURE DOSING IN-GROUND BED – 3 BEDROOMS – 31MIN/INCH

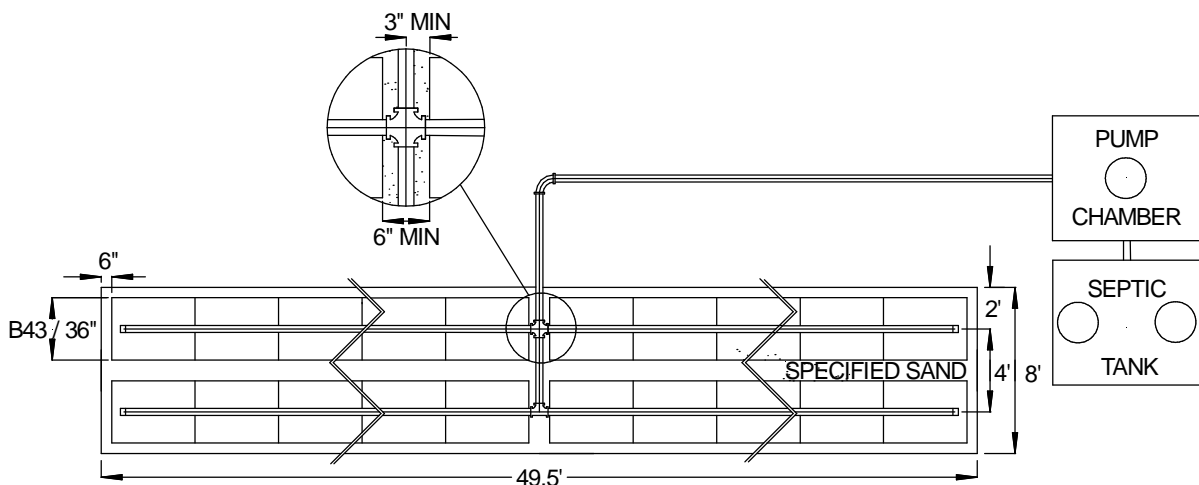

GSF Sizing Example – Pressure Dosed Mound Design

Example #6 Pressure Dosing Mound Design

House size – 3 bedrooms
Design Flow – 400 gpd (Chapter 73.17)
Percolation Rate – 61 min/in
Slope - 6%

Determine the square feet of bed per gallon per day:

Absorption area (ft²) based on the percolation rate and peak daily flow.

For a percolation rate of 61 min/in: ((Avg. Perc Rate - 60) x (0.020) + 2.22) = 2.24 ft² per gallon (gal).

Absorption area of a bed for 3 bedroom: 400 gal/day x 2.24 ft²/gal = 896 ft².

No reduction for bed area (Perc Rate >60 mpi): 896 ft².

Determine number of modules: The B43 Module Basal Area is 24 ft² for percolation rates from 61 min/in – 180 min/in.

Number of Modules = Reduced Trench Area ÷ B43 Basal Area: 896 ft² ÷ 24 ft² = 37.3, use 38 Modules.

Calculate Bed Length:

(Number of Modules ÷ Number of Rows x 4 ft) + 1 ft of Specified Sand + 0.5 ft Lateral Offset = Bed Length.

2 Rows: 38 Modules ÷ 2 Rows = 19 Modules, use 19 Modules: 19 Modules x 4 ft + 1 ft + 0.5 ft = 77.5 ft Bed Length

Calculate Approximate Bed Width (for this example, we decided to use two rows):

Divide the bed area in square feet by bed length: 896 ft² ÷ 77.5 ft = 11.5 ft wide.

Determine the Module Row Spacing and Bed Width:

Minimum center to center separation distance between rows for percolation rates between 61 – 180 min/in = 6 ft

Minimum distance from sidewall = 3 ft

Bed Width = 2 x (Minimum Distance from Sidewall) + ((Number of Rows – 1) x (Minimum separation distance between rows)) Bed Width = (2 x 3) + (1 x 6) = 12 ft

Final Bed Layout Dimensions:

Length =	77.5 ft
Width =	12 ft
Installed Area =	930 ft ²
Number of Rows =	2
Number of Modules =	38 B43
Center – Center Spacing =	6 ft
Edge – Center Spacing =	3 ft

GSF Sizing Example – Pressure Dosed Mound Design

FIGURE 10: B43 PRESSURE DOSED MOUND DESIGN – 3 BEDROOMS – 61 MIN/INCH

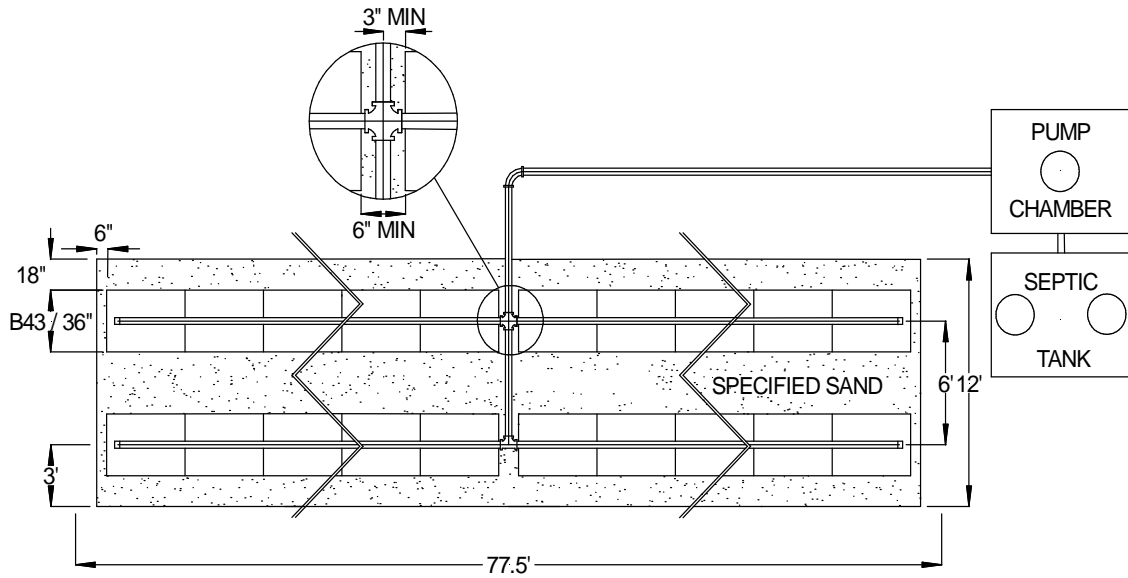
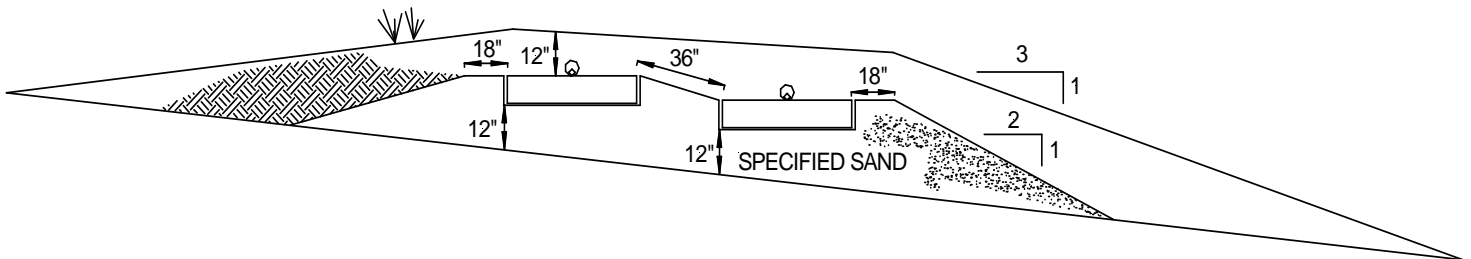

FIGURE 11: B43 PRESSURE DOSED MOUND DESIGN – 3 BEDROOMS – 61 MIN/INCH

NOTE: GSF Modules can be installed on a level pad or "stepped" as shown below. For level examples see Figures 14 - 16



GSF Sizing Example – Less than 20 Inches from Limiting Horizon

Example #7 Less than 20 Inches from Limiting Horizon

House size –	3 bedrooms
Design Flow –	400 gpd (Chapter 73.17)
Slope on the Limiting Horizon –	12%
Distance from Limiting Horizon –	15 in

Soil Characteristics

Texture -	Silt Loam (SIL)
Structure	
Shape -	Fine Subangular Blocky (BK)
Grade -	Friable, Weak (1)

Determine the Infiltration Loading Rate (gal/ft²/day):

Refer to the Hydraulic Linear Loading Rate Table (Appendix 5 of the Alternate Systems Guidance, Commonwealth of Pennsylvania, Department of Environmental Protection) to determine the Infiltration Loading Rate. Use the Soil Characteristics to determine the rate.

0.6 gal/ft²/day

Determine the Hydraulic Linear Loading Rate (gal/ft/day):

Refer to the Hydraulic Linear Loading Rate Table (Appendix 5 of the Alternate Systems Guidance, Commonwealth of Pennsylvania, Department of Environmental Protection) to determine the Hydraulic Linear Loading Rate. Use the Infiltration Loading Rate and information about the Limiting Horizon to determine the rate.

3.5 gal/ft/day

Determine Required Length of Bed: (Design Flow ÷ Hydraulic Linear Loading Rate)

$(400 \text{ gpd} \div 3.5 \text{ gpd/ft}) = 114.3 \text{ ft}$, round up to 115 ft.

Determine Width of Bed: Hydraulic Linear Loading Rate ÷ Infiltration Loading Rate

Bed width cannot be less than 4 ft. If the required trench width is smaller, increase to a 4 ft width.

$3.5 \text{ gpd/ft} \div 0.6 \text{ gpd/ft}^2 = 5.8 \text{ ft}$, round up to 6 ft.

Calculate the Number of Modules:

Number of Modules = Trench Length ÷ 4 ft/module

Number of Modules = $115 \text{ ft} \div 4 \text{ ft} = 28.75$ Modules, Round up to 29.

Determine Actual Trench Length:

Modules x Length of Module + 1 ft of Specified Sand at row ends + 0.5 ft Lateral Offset =

$29 \text{ Modules} \times 4 \text{ ft} + 1 \text{ ft} + 0.5 \text{ ft} = 117.5 \text{ ft}$

Actual Absorption Area: Actual trench length x Width of Trench

$117.5 \text{ ft} \times 6 \text{ ft} = 705 \text{ ft}^2$

Final Bed Layout Dimensions:	
Length =	117.5 ft
Width =	6 ft
Installed Area =	705 ft ²
Number of Modules =	29 B43

2.0 Trench Installation Guidelines

Additional guidance Chapter 73. Standards, § 73.52

Determine the Number Modules	Determine the number of GSF Modules required. Reference sizing examples in this manual.
Determine Trench Dimensions	Calculate the length, width and number of trenches using the sizing examples. The maximum single trench length in Pennsylvania is 100 ft.
Plan all Drainage Requirements	Plan all drainage requirements up-slope of the system. Set soil grades to ensure that storm water drainage and ground water is diverted away from the absorption area once the system is complete.
Excavating the Trench Area	Scarify the receiving layer to maximize interface between the native soil and Specified Sand. Minimize walking in the trench prior to placement of the Specified Sand to avoid soil compaction.
Placing Specified Sand Base	Place Specified Sand in two 6 inch lifts into the bed, compact each lift at a time. The compacted height below the GSF module must be level at 12 inches. A hand tamping tool or vibrating compactor is acceptable.
Place GSF Modules	Place the GSF Modules end to end on top of the specified sand along their 4-foot length, <i>PAINTED STRIPE FACING UP.</i>
Distribution Pipes: Gravity & Pressure Dosed Systems	A standard 4-inch perforated pipe, SDR 35 or equivalent, is centered along the modules 4-foot length. Orifices are set at the 5 & 7 o'clock positions. All 4-inch pipes are secured with manufacturers supplied wire clamps, one per module. Section 1.5 of this manual has more information on pipe selection.
Distribution Pipes: Pressure Distribution Systems	A standard 4-inch perforated pipe, SDR 35 or equivalent, is centered along the modules 4-foot length. Orifices are set at the 5 & 7 o'clock positions. Insert a 1.5 inch low pressure pipe (LPP) into the standard 4-inch perforated pipe. The LPP orifices are set at the 12 o'clock position as shown in Figure 21. A ¼ inch diameter drain hole is required at the 6 o'clock position of each pressure lateral for drainage purposes. All 4-inch pipes are secured to the modules with manufacturers supplied wire clamps, one per module.
Place Geotextile Cover Fabric	Spread Eljen supplied cover fabric lengthwise over the pipe and drape over the sides of the GSF module rows. Secure in place with Specified Sand between and along the sides of the modules. Avoid blocking holes in perforated pipe by placing the cover fabric over the pipe prior to placing fill over the modules.
Placing Specified Sand after Cover Fabric is in place	Place 6 inches minimum of Specified Sand along both sides of the modules edge when percolation rates are between 3 – 60 min/in. Place 18 inches of Specified Sand along both sides of the modules edge when percolation rates are between 61 – 180 min/in. A minimum of 6 inches of Specified Sand is placed at the beginning and end of each row.
Backfilling the System	Complete backfill with topsoil, 12 - 18 inches over the GSF modules. Backfill exceeding 18 inches requires venting at the distal end of the system. Fill must be clean, porous and devoid of rocks. Do not use wheeled equipment over the system during backfill operation. A light track machine may be used with extreme caution, avoiding crushing or shifting of pipe assembly. Divert surface runoff. Finish grade to prevent surface ponding. Use backfill material that is soil suitable for the growth of vegetation, and be seeded to control erosion.

3.0 Bed Installation Guidelines

Additional guidance Chapter 73. Standards, § 73.53

Determine the Number Modules	Determine the number of GSF Modules required. Reference sizing examples in this manual.
Plan all Drainage Requirements	Plan all drainage requirements above (up-slope) of the system. Set soil grades to ensure that storm water drainage and ground water is diverted away from the absorption area once the system is complete.
Excavating the Bed Area	Scarify the receiving layer to maximize the interface between the native soil and Specified Sand. Minimize walking in the trench prior to placement of the Specified Sand to avoid soil compaction.
Placing Specified Sand Base	Place Specified Sand in two 6 inch lifts into the bed, compact each lift at a time. The compacted height below the GSF module must be level at 12 inches. A hand tamping tool or vibrating compactor is acceptable.
Place GSF Modules	Place the GSF Modules end to end on top of the specified sand along their 4-foot length, PAINTED STRIPE FACING UP .
Distribution Pipes: Gravity & Pressure Dosed Systems	A standard 4-inch perforated pipe, SDR 35 or equivalent, is centered along the modules 4-foot length. Orifices are set at the 5 & 7 o'clock positions. All 4-inch pipes are secured with manufacturers supplied wire clamps, one per module. Section 1.5 of this manual has more information on pipe selection.
Distribution Pipes: Pressure Distribution Systems	A standard 4-inch perforated pipe, SDR 35 or equivalent, is centered along the modules 4-foot length. Orifices are set at the 5 & 7 o'clock positions. Insert a 1.5 inch low pressure pipe (LPP) into the standard 4-inch perforated pipe. The LPP orifices are set at the 12 o'clock position as shown in Figure 21. A ¼ inch diameter drain hole is required at the 6 o'clock position of each pressure lateral for drainage purposes. All 4-inch pipes are secured to the modules with manufacturers supplied wire clamps, one per module.
Place Geotextile Cover Fabric	Spread Eljen cover fabric lengthwise over the pipe and drape over the sides of the GSF module rows. Secure in place with Specified Sand between and along the sides of the modules. Avoid blocking holes in perforated pipe by placing the cover fabric over the pipe prior to placing fill over the modules.
Placing Specified Sand after Cover Fabric is in place	Place 6 inches minimum of Specified Sand along both sides of the modules edge when percolation rates are between 3 – 60 min/in. Place 18 inches of Specified Sand along both sides of the modules edge when percolation rates are between 61 – 180 min/in. A minimum of 6 inches of Specified Sand is placed at the beginning and end of each row.
Backfilling the System	Complete backfill with topsoil, 12 - 18 inches of cover over the GSF modules. Backfill exceeding 18 inches requires venting at the distal end of the system. Fill must be clean, porous and devoid of rocks. Do not use wheeled equipment over the system during backfill operation. A light track machine may be used with extreme caution, avoiding crushing or shifting of pipe assembly. Divert surface runoff. Finish grade to prevent surface ponding. Use backfill material that is soil suitable for the growth of vegetation, and be seeded to control erosion.

4.0 Elevated GSF Sand Mound Installation Guidelines

Additional guidance see Chapter 73. Standards, § 73.55. -- §73.46.

Determine the Number Modules	Determine the number of GSF Modules required. Reference sizing examples in this manual.
Excavating the Bed Area	Scarify the receiving layer to maximize the interface between the native soil and Specified Sand. Minimize walking in the trench prior to placement of the Specified Sand to avoid soil compaction.
Placing Specified Sand Base	Place Specified Sand in two 6 inch lifts, compact each lift at a time. The compacted height below the GSF module must be level at 12 inches. A hand tamping tool or vibrating compactor are both acceptable.
Place GSF Modules	Place the GSF Modules end to end on top of the specified sand along their 4-foot length, <i>PAINTED STRIPE FACING UP.</i>
Distribution Pipes: • Pressure Dosed • Siphons • Pressure Distribution	A standard 4-inch perforated pipe, SDR 35 or equivalent, is centered along the modules 4-foot length. Orifices are set at the 5 & 7 o'clock positions. Insert a 1.5 inch low pressure pipe (LPP) into the standard 4-inch perforated pipe. The LPP orifices are set at the 12 o'clock position as shown in Figure 21. A ¼ inch diameter drain hole is required at the 6 o'clock position of each pressure lateral for drainage purposes. All 4-inch pipes are secured to the modules with manufacturers supplied wire clamps, one per module.
Pump Chamber to the GSF System	Refer to guidance in this manual for <ul style="list-style-type: none"> • Pressure Dosed Guidance • Pressure Distribution Guidance • Pump Controls • Figures
Place Geotextile Cover Fabric	Spread Eljen cover fabric lengthwise over the pipe and drape over the sides of the GSF module rows. Secure in place with Specified Sand between and along the sides of the modules. Avoid blocking holes in perforated pipe by placing the cover fabric over the pipe prior to placing fill over the modules.
Backfilling the System	Complete backfill with topsoil, 12 - 18 inches over the GSF modules. Backfill exceeding 18 inches requires venting at the distal end of the system. Fill must be clean, porous and devoid of rocks. Do not use wheeled equipment over the system during backfill operation. A light track machine may be used with extreme caution, avoiding crushing or shifting of pipe assembly. Divert surface runoff. Finish grade to prevent surface ponding. Use backfill material that is soil suitable for the growth of vegetation, and be seeded to control erosion.

Mound Drawings

FIGURE 14: B43 SINGLE LATERAL MOUND SYSTEM
3 MIN/IN – 60 MIN/IN PERCOLATION RATE
ZONES GREATER THAN 20 INCHES

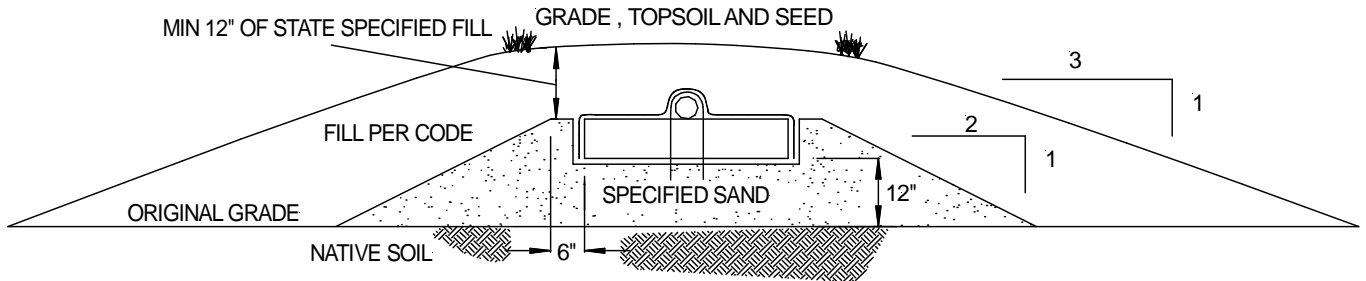

FIGURE 15: B43 MULTIPLE LATERAL MOUND SYSTEM
3 MIN/IN – 60 MIN/IN PERCOLATION RATE FOR LIMITING
ZONES GREATER THAN 20 INCHES

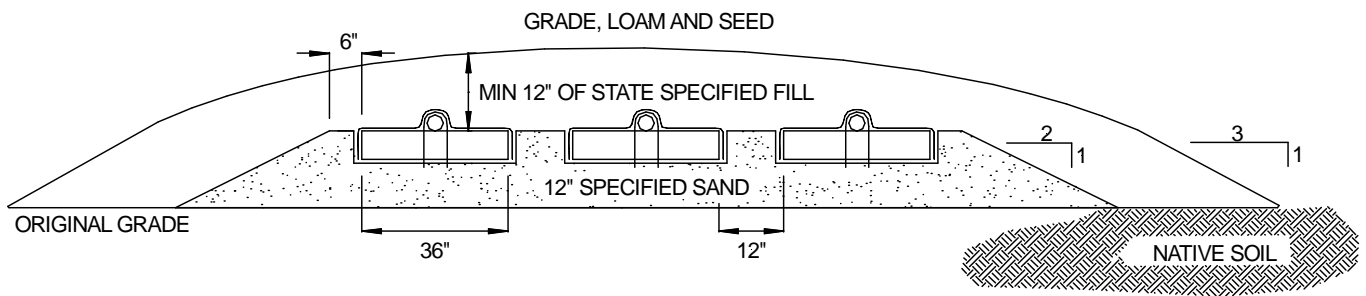
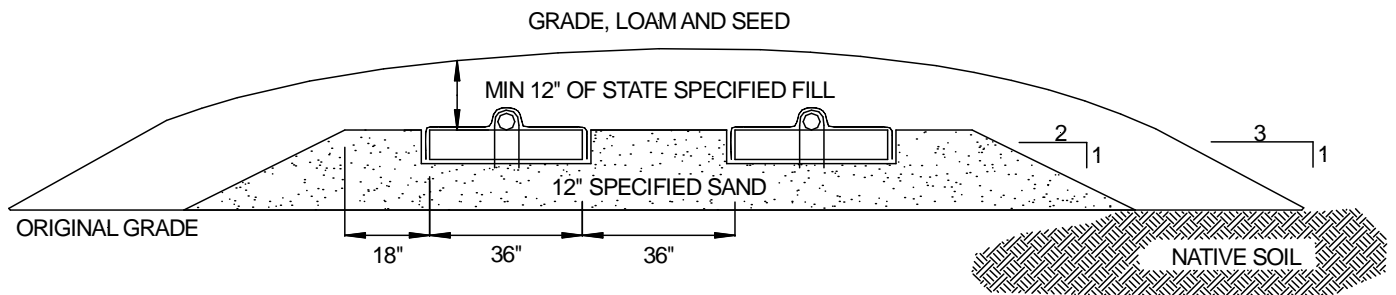

FIGURE 16: B43 MULTIPLE LATERAL MOUND SYSTEM
61 MIN/IN – 180 MIN/IN PERCOLATION RATE FOR LIMITING
ZONES GREATER THAN 20 INCHES



Note for All Systems:

Systems may be installed level or "stepped" on sloping sites. See Figure 11 for "stepped" example.

6 inches minimum of Specified Sand is required at the beginning and end of each GSF Trench.

12 inches minimum of Specified Sand is required directly below the GSF module.

A minimum 12 inches of clean fill, specified by the state, is required above modules.

Either 6 inches or 18 inches of Specified Sand is required at the edges of the GSF Modules.

5.0 Dosing Distribution Guidance

5.1 DOSING DESIGN CRITERIA: Use a maximum of 4 gallons per dose per B43 Module in the system.

5.2 SYSTEMS WITH VENTING REQUIREMENTS: Pump systems with more than 18 inches of cover material as measured from the top of the module to finished grade, require venting and an additional bypass line from the distribution box back to a knock out or a riser on the septic tank or pump chamber. Refer to Figures 25 and 26 for these illustrations.

5.3 ADDITIONAL GUIDANCE: The maximum B43 Module loading rate on the module top surface shall not exceed 30 gallons per day per module. Adjust pump gallons per minute and run time to achieve the above maximum dose.

FIGURE 17: LIFT PUMP TO DISTRIBUTION BOX – GRAVITY FED – PLAN VIEW

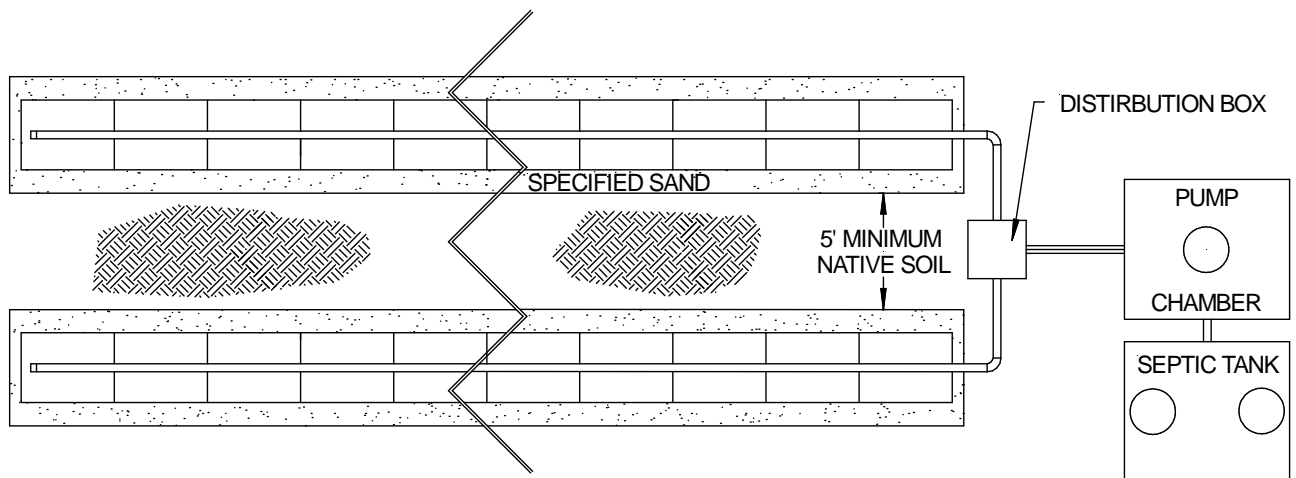

6.0 Pressure Distribution Guidance

6.1 DOSING DESIGN CRITERIA: Use a maximum of 4 gallons per dose per B43 Module in the system. Adjust pump gallons per minute and run time to achieve the above maximum dose.

6.2 STANDARD PROCEDURES: Standard procedures for design of pressure distribution networks apply to the GSF filter. Minimum orifice and lateral pipe size is accordance with the *Guidelines*, 73.44, b, 5. A ¼ inch diameter drain hole is required at the 6 o'clock position of each pressure lateral for drainage purposes. A standard 4-inch perforated pipe, SDR 35 or equivalent, is centered along the modules 4-foot length. Orifices are set at the 5 & 7 o'clock position. Insert a 1.5 inch pressure pipe into the standard 4-inch perforated pipe. The pressure pipe orifices are set at the 12 o'clock position as shown in Figure 21. At least one drain hole per line at the 6 o'clock position must added to each line. All 4-inch pipes are secured to the modules with manufacturers supplied wire clamps, one per module.

6.3 SYSTEMS WITH VENTING REQUIREMENTS: Pump systems with more than 18 inches of cover material as measured from the top of the module to finished grade, require venting and an additional bypass line from the distribution box back to a knock out or a riser on the septic tank or pump chamber. Refer to Figures 25 and 26 for these illustrations.

6.0 Pressure Distribution Guidance

6.4 LOW PRESSURE DISTRIBUTION: Pressure distribution lines and orifice sizing and spacing should be based on design or code. Design requirements will vary depending on length of system and dose volume. At least one drain hole per line at the 6 o'clock position must be added to each line. Eljen recommends that timed pressure distribution systems be designed by a qualified person. See Figures below for examples of Low Pressure Distribution drawings.

Flushing ports are required at the distal end of all pressure distribution networks. Flushing valves and vents can be consolidated in larger systems by using valves on the outlet manifold.

FIGURE 18: PRESSURE PIPE PLACEMENT

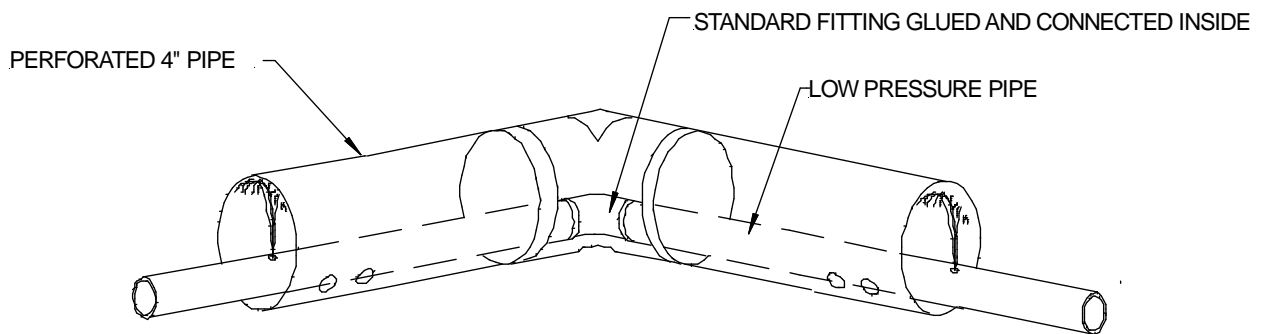

Pressure Pipe placement when following contours or changes in trench direction.

6.0 Pressure Distribution Guidance

FIGURE 19: CONTOURED TRENCH PRESSURE DISTRIBUTION

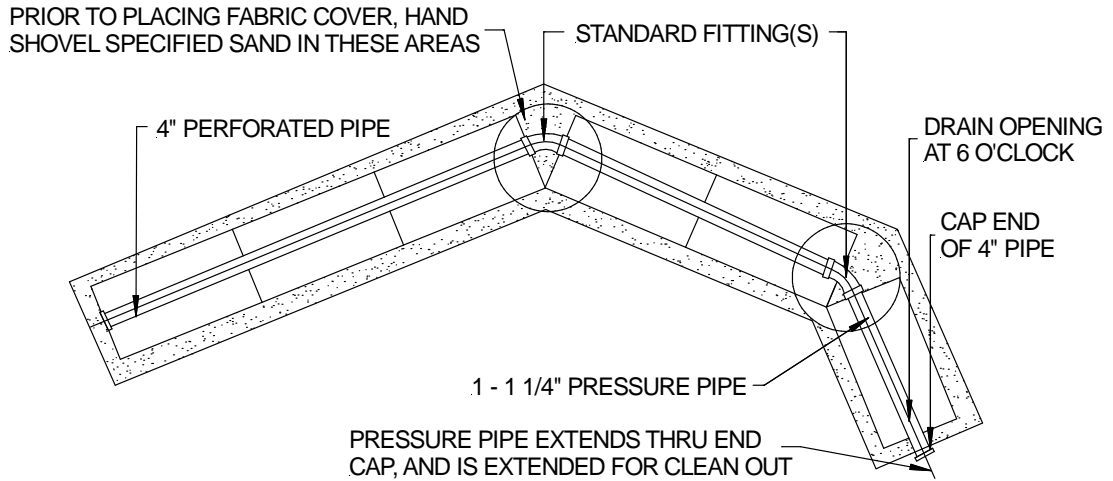

GSF Pressure Distribution Trench System can be placed along a contour or in winding trenches to follow natural grade and maintain horizontal separation distances from setbacks or other constraints. This method is also applicable for Dosed, Gravity, or Pressure Distribution systems.

FIGURE 20: PLAN VIEW FOR PRESSURE DISTRIBUTION

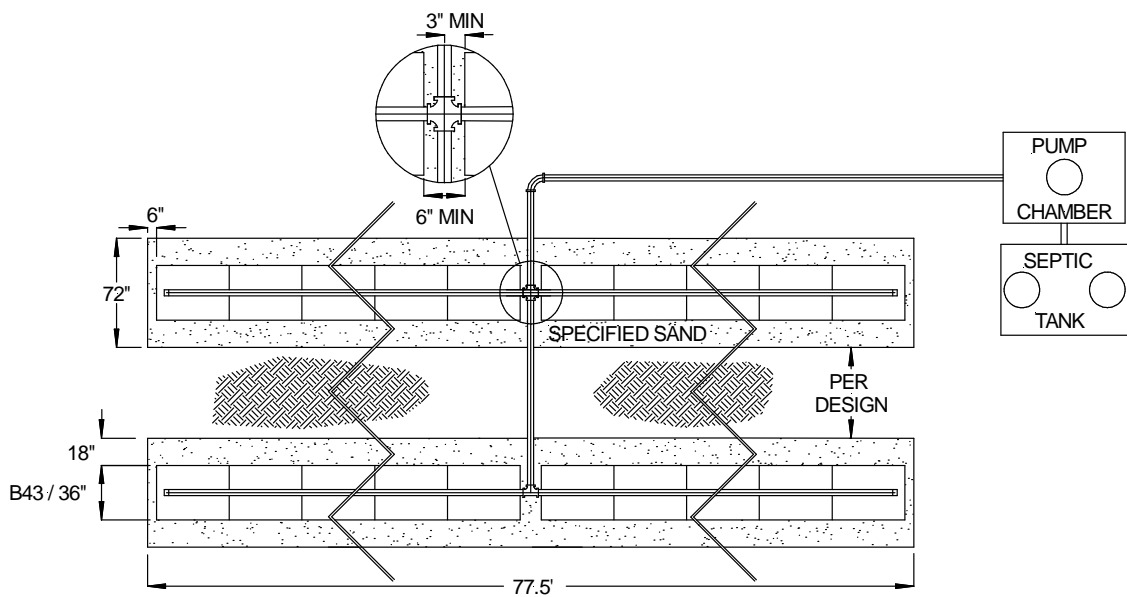

6.0 Pressure Distribution Guidance

FIGURE 21: EXAMPLE PRESSURE DISTRIBUTION

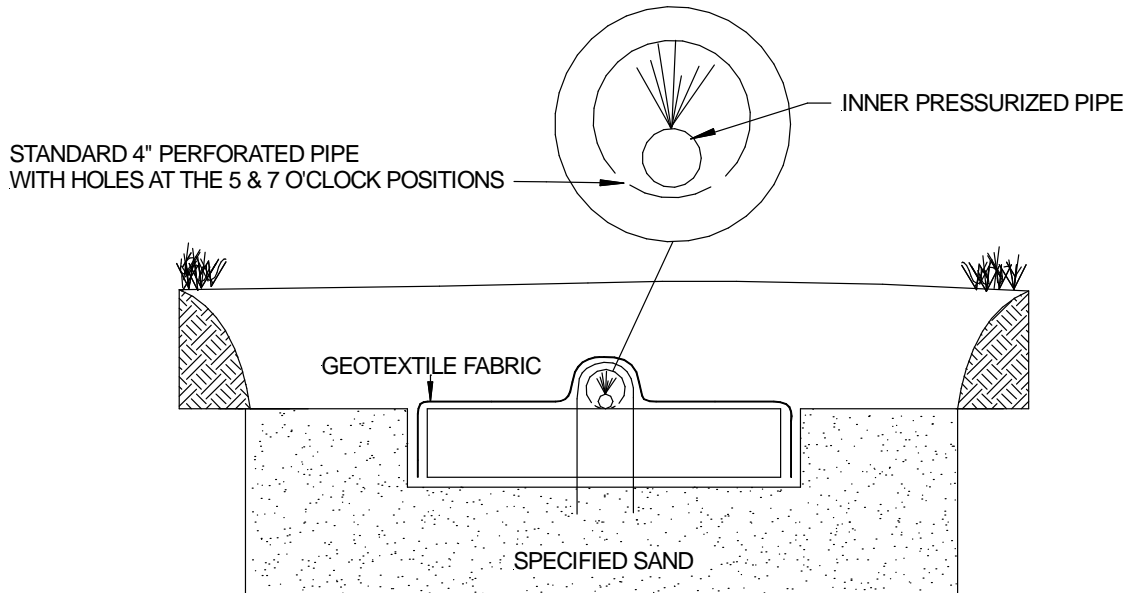

6.0 Pressure Distribution Guidance

FIGURE 22: PRESSURE CLEAN OUT PRESSURE DOSED SYSTEM

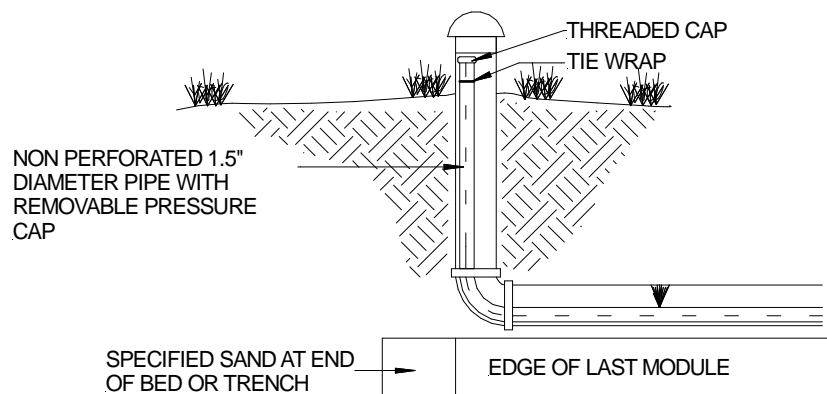

7.0 Pump Controls

7.1 ELECTRICAL CONTROLS: Demand and Pressure Dosed controlled systems will include an electrical control system that has the alarm circuit independent of the pump circuit, controls and components that are listed by UL or equivalent, is located outside, within line of sight of the pump chamber and is secure from tampering and resistant to weather (minimum of NEMA 4). The control panel shall be equipped with features that record historical pump operation information..

The control panel shall be equipped with both audible and visual high liquid level alarms installed in a conspicuous location. Float switches shall be mounted independent of the pump and transport line so that they can be easily replaced and/or adjusted without removing the pump.

8.0 System Ventilation

8.1 SYSTEM VENTILATION: Air vents are required on all absorption systems located under impervious surfaces or systems with more than 18 inches of cover material as measured from the top of the GSF Module to finished grade. This will ensure proper aeration of the modules and sand filter. Under normal operating conditions, only a fraction of the filter is in use. The unused portion of the GSF remains open for intermittent peak flows and the transfer of air. The extension of the distribution pipe to the vent provides adequate delivery of air into the GSF system, as shown in Figures 23 & 24.

Home plumbing operates under negative pressure due to hot water heating the pipes and reducing the density of air in the house vent. As hot air rises and exits the home, it must be replaced by air from the GSF. To maintain this airflow and fully aerate the GSF system, it is important that air vents are located only on the distal end of the GSF pipe network.

If a pressure or demand dosed system is specified with greater than 18 inches of cover, an additional 2-inch minimum air line must be extended from the GSF D-box back to a knockout or riser on the septic tank or pump chamber. This maintains the continuity of airflow from the field into the house plumbing.

In a gravity fed GSF system, the vent is usually a 4-inch diameter pipe extended to a convenient location behind shrubs, as shown in Figure 24. Corrugated pipe can be used with the placement and grade such that any condensation that may accumulate in the pipe does not fill and thus close off this line. If the vent is extended, the pipe must not drain effluent and must have an invert higher than the system.

Pump systems with more than 18 inches of cover material as measured from the top of the module to finished grade, require venting and an additional bypass line from the distribution box back to a knock out or a riser on the septic tank or pump chamber. Refer to Figures 25 and 26 for these illustrations.

System Ventilation Example Drawings

FIGURE 23: VENT FOR GRAVITY AND DEMAND DOSED SYSTEMS

NOTE: For systems with greater than 18 inches of cover.

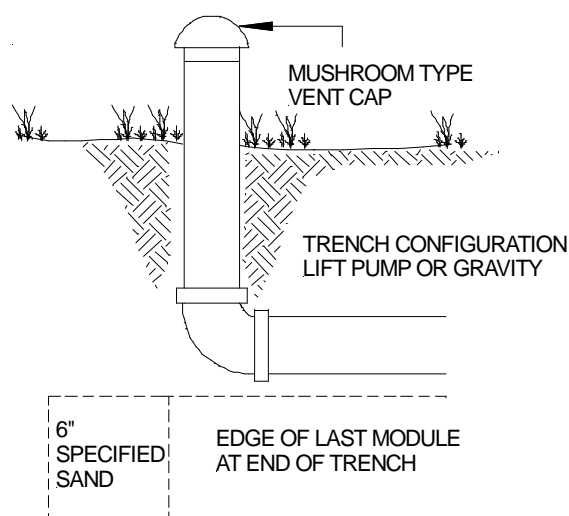

System Ventilation Example Drawings

FIGURE 24: GSF WITH 4" VENT EXTENDED TO CONVENIENT LOCATION

NOTE: For systems with greater than 18 inches of cover.

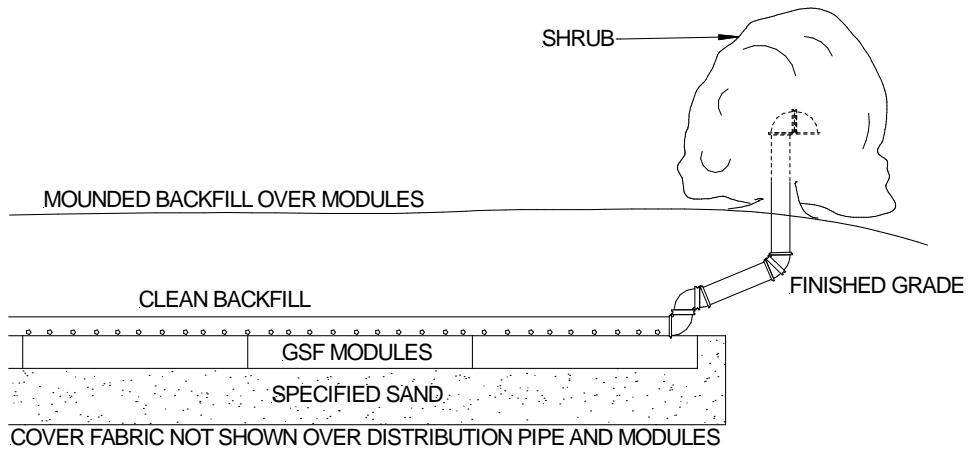
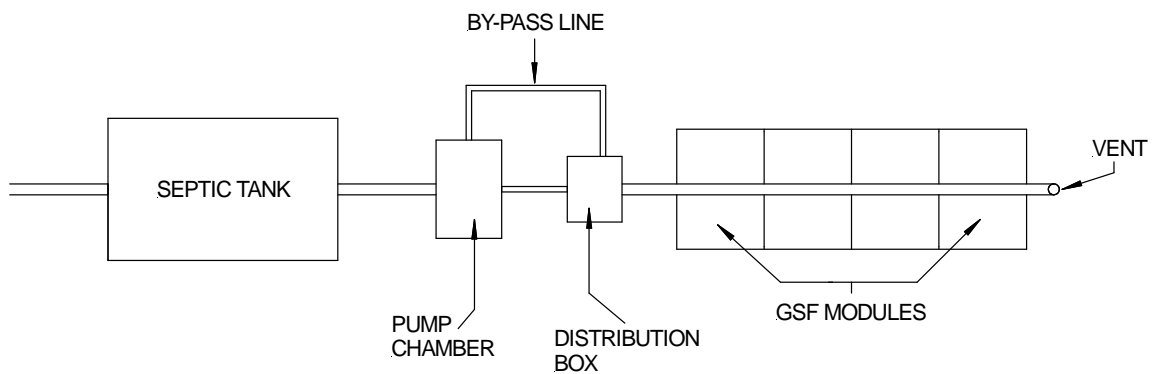

FIGURE 25: AIR BY-PASS LINE PLAN VIEW; VENTING OF PUMPED SYSTEMS

NOTE: For systems with greater than 18 inches of cover.



System Ventilation Example Drawings

FIGURE 26: AIR BY-PASS LINE CROSS SECTION; VENTING OF PUMPED SYSTEM

NOTE: For systems with greater than 18 inches of cover.

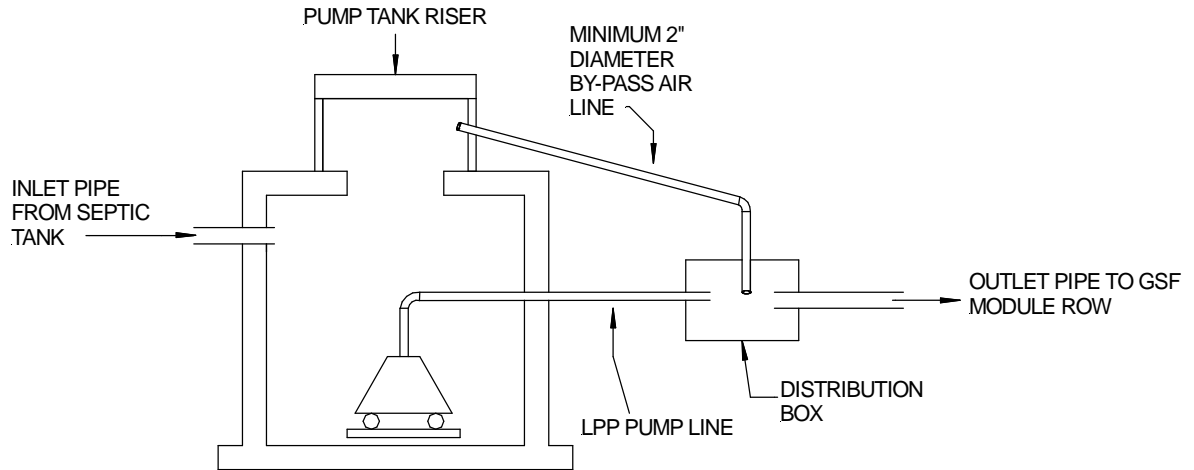

TABLE 3: GSF INSPECTION CHECK LIST

Geotextile Sand Filter, (GSF) Checklist					
Facility Owner:					
Facility Address:					
Installation Date: (MDY)					
Previous Inspection Date: (MDY)					
Date of Inspection : (MDY)					
Residential Number of Bedrooms:					
Is this a Commercial Design? If yes what type:	Yes	No			
What is the estimated BOD5 and TSS strength?	BOD5	TSS	Comments		
Observation Port Location(s):	1	2	3		
Inspection Data, (complete all fields)					
Is daily flow within the system design flow? If no, explain:	Yes	No			
Does the owner verify the system use as described above? If no, explain:	Yes	No			
Septic tank last inspection date:	Date				
Inspected by:					
Septic tank last pumped date:					
Is pumping recommended?	Yes	No			
Condition of the soil absorption system: Wet, Dry, Firm, Soft, Vegetative, or Other. If Other, explain:	W	D	S	F	V
Is there evidence of storm water flows or erosion over the septic system? If yes, explain:	Yes	No			

TABLE 3: GSF Inspection Check List (continued)

Is there evidence of soil slump or compaction by traffic or other means in the vicinity of the soil absorption system? If yes, describe:	Yes	No	Comments
Is effluent visible through the observation port? If yes, describe the condition and the fluid level:	Yes	No	Comments
Is there a garbage disposal in the home?	Yes	No	Comments
Is a water softer connected to the system?	Yes	No	Comments
Are solids visible through the observation port? If yes, describe the condition and depth of solids:	Yes	No	Comments
Is there evidence of surcharging or effluent ponding in the D-Box? If yes, describe and measure:	Yes	No	Comments
Are the system vents in place?	Yes	No	Comments
Are they operational? If no, describe conditions and location:	Yes	No	
Describe any other pertinent issues:			

Inspected by:	
License Number:	
Date:	
Time:	
Print Name & Signature of Inspector:	
<i>I certify I have inspected the system at the above address, completed this report, and the information reported is true, accurate, and complete.</i>	

Eljen Installation Check List

Prior to final backfill over the GSF modules, ensure that all of the installation check points listed below have been completed.

ALL SYSTEMS

1. Each line or row of the system is level.
2. Ensure that the painted white stripe is facing up on each module.
3. Verify there is a minimum of 12 inches of Specified Sand underneath each module in the system.
4. Based on the system design, verify the appropriate amount of Specified Sand is installed between module rows in bed systems, and along the 4-foot module length in trench systems.
5. Ensure there is a minimum of 6 inches of Specified Sand at the beginning and end of module rows in bed or trench systems.
6. The 4-inch perforated pipe on top of the module is SDR-35 or equivalent.
7. The perforated 4-inch pipe has orifices at 5 & 7 o'clock over the modules.
8. The wire clamps that fit over the 4-inch distribution pipe are installed, one per module.
9. The cover fabric is placed over the 4-inch perforated pipe, and draped over the sides of each module prior to Specified Sand placement around modules. The cover fabric shall NOT be pulled tightly over the 4-inch perforated pipe, which causes tenting.

PRESSURE DISTRIBUTION ONLY

1. In the 1.5-inch LPP, there is at least one drain hole at the 6 o'clock position.
2. The LPP has its orifices at the 12 o'clock position.
3. The 4-inch perforated pipe has holes at 5 & 7 o'clock.
4. Verify that there is a minimum of 3 feet of head at the terminal end of each lateral.